

Robertshaw®

**B10 SERIES
5210 SERIES**

**ELECTRIC
THERMOSTAT**



The Robertshaw® B10 series is a direct acting, single pole, slow make and break type thermostat. Typical applications are for incubators, laboratory ovens, water baths, sterilizers, dishwashers, steam tables, scalding tanks and other equipment where a close temperature differential is required.

Features and Benefits

- Temperature ranges to 550°F (288°C)
- Single pole, slow make and break design
- Very sensitive to temperature change
- Small temperature differential between make and break
- Fine silver contacts to assure consistent switch action and long life
- Rugged and compact design for versatility of application
- Bulb and capillary available in copper, nickel plated copper, or stainless steel
- Plastic coating available to protect against moisture, dust, etc.

Specifications

- Ambient temperature: 32°F to 150°F (0°C to 66°C)
- Electrical Rating:
 - 20 Amps @ 125 VAC
 - 15 Amps @ 250 VAC
 - 125VA PD @ 125 VAC
- Agency Certification Numbers:
 - UL File No. E12103
 - CSA File No. LR36461

AVAILABLE BULB DIAMETERS

inches	0.187	0.250	0.312	0.375
[millimeters]	4,8	6,4	7,9	9,5



An ISO 9001 – 2008 Certified Company

PRODUCT DIMENSIONS

Dimensions are inches and [millimeters].

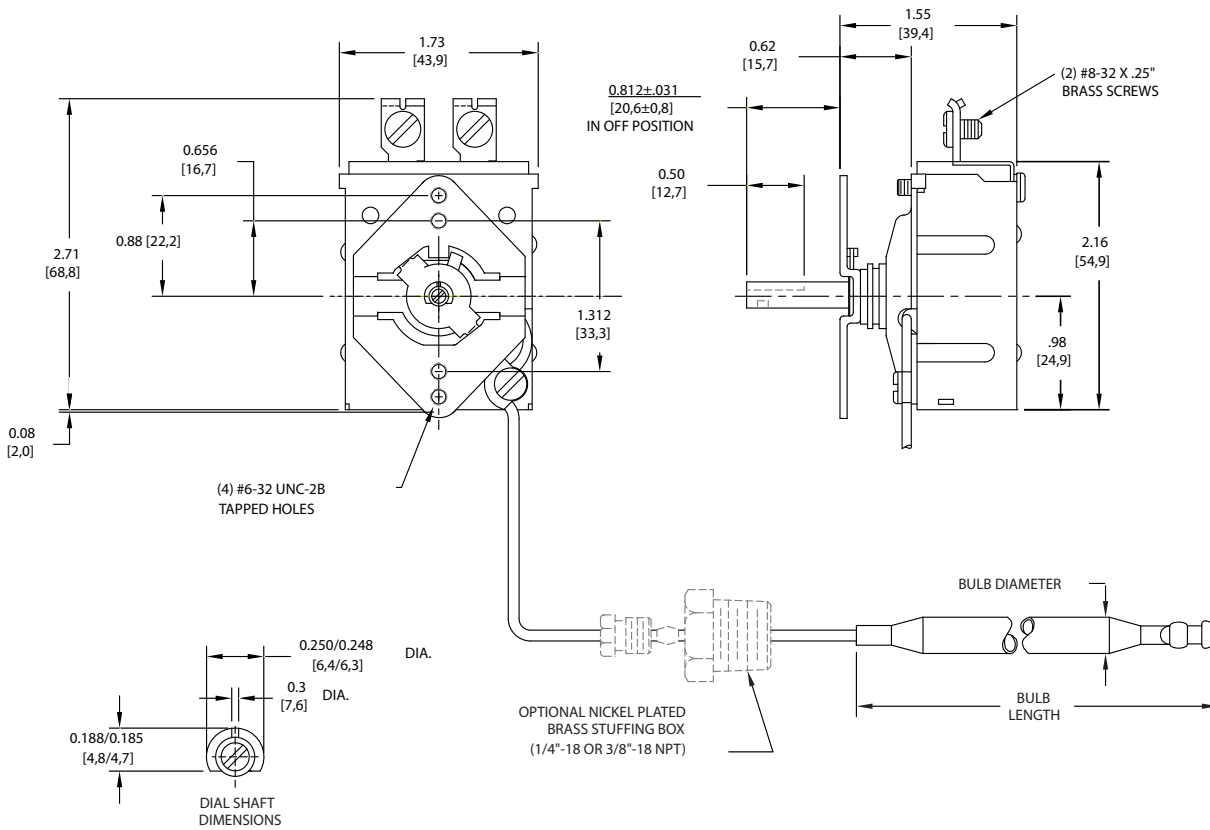

WIRING DIAGRAMS

PILOT LIGHT (OPTIONAL) IS ON WHEN THERMOSTAT SWITCH IS OFF

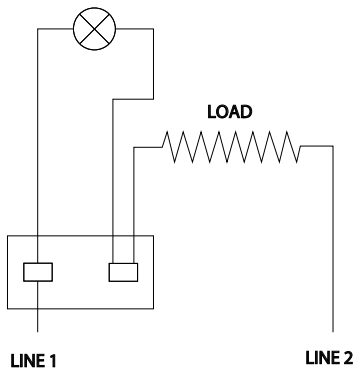

PILOT LIGHT (OPTIONAL) IS OFF WHEN THERMOSTAT SWITCH IS OFF

