

DW-952

The Robertshaw® S-45 Water Valve Series is designed as a general purpose valve for energy conserving plumbing and heating applications.

Features and Benefits

- Pilot-operated design provides flow capacity with minimum power requirements
- Serviceable strainer incorporated for the protection of both the valve and the appliance
- Encapsulated coil provides high mechanical and dielectric strength, and is moisture resistant
- UL requirements met for intermittent duty operation
- Suitable for applications using water at temperatures up to 160°F (71°C)

REPLACEMENT INFORMATION

Part Numbers	Replaces	Factory Number
DW-952	Moyer Diebel 504952	K-62687-44
IMV-001	Scotsman 12-2990-01	K-62687-128
PL-849	Sloan Valve 0305849	K-77634

SPECIFICATIONS

Part Numbers	Description	Flow Rate	Inlet	Outlet	Operating Pressure	Terminals	Body Material	Electrical Rating	Power
DW-952	Commercial Dishwasher Water Valve S-45	Up to 5 GPM	3/8" 18 FNPT	3/8" 18 FNPT	20 PSI to 120 PSI	1/4" Male	Brass	120V AC 50/60 Hz	10 Watts
IMV-001	Commercial Ice Maker Water Valve S-45	0.19 GPM	3/8" 18 FNPT	3/8" ID Hose	20 PSI to 120 PSI	1/4" Male	Brass	120V AC 60 Hz	15 Watts
PL-849	Commercial Plumbing Water Valve S-45	NA	3/8" 18 FNPT	3/8" 18 FNPT	20 PSI to 120 PSI	1/4" Male	Low Lead Brass	24V AC 50/60 Hz	7 Watts

PRODUCT DRAWINGS

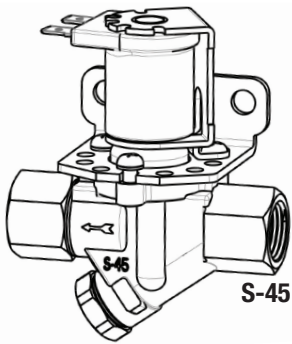

S-45

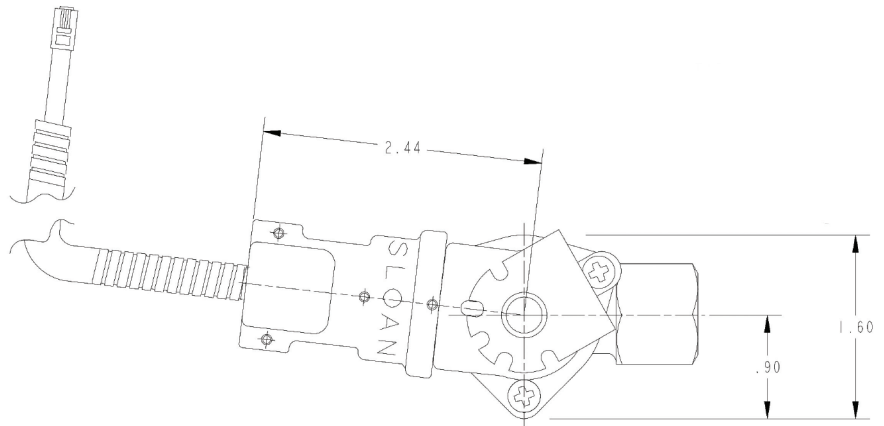

S-45
with Connector

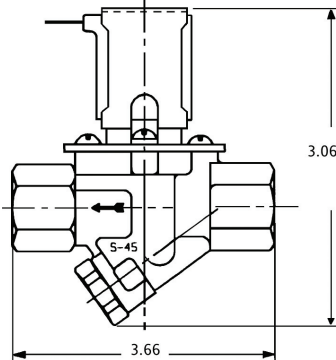

APPROXIMATELY
20" IN LENGTH

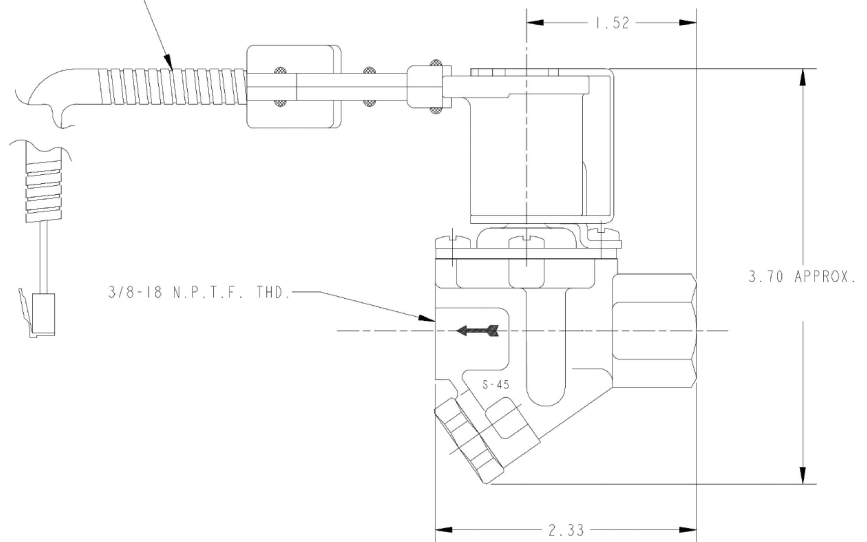

S-45
with Connector

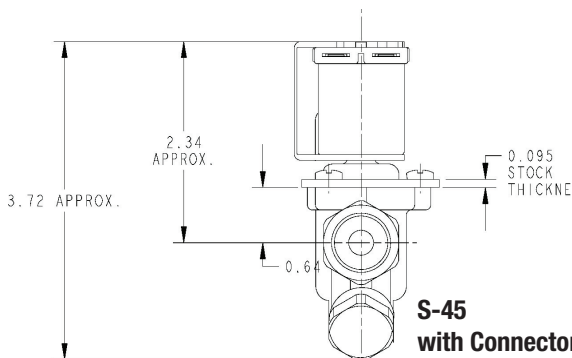

S-45
with Connector